



238 Pillow Street
Butler, PA 16001
724-283-4681
724-283-5939 (fax)
www.bwieagle.com

PRODUCT INFORMATION BULLETIN

EAGLE 2 Dual Channel Speed Switch MODEL 11-7000

DESCRIPTION

The Eagle 2 is a dual channel critical speed switch that monitors speed and detects motion in all types of rotating electrical apparatus. Models are available to meet any application requirement for underspeed, overspeed and zero speed. The rugged NEMA enclosure meets virtually any industrial environmental challenge. Ideal for conveyors, crushers, fans, motors and other rotating apparatus.

INSTALLATION

DISCONNECT AC Power before proceeding with instructions.

1. Mount the EAGLE 2 control unit in a convenient location.
2. Make the following connections:
 - A. Connect power cable to 120VAC.
 - B. Connect control cables to proper terminals in the motor control circuit.
 - C. Connect EAGLE SENSOR cables to the sensor connectors on the control unit.
3. Install sensors at rollers. See sensor installation section.

SET-UP AND TESTING

Final calibration should be performed with the belt loaded and running at normal speed.

1. Turn TRIP ADJUST pot counterclockwise until it stops. (approximately 7 o'clock).
2. Hold switch in SET position to energize relay.
3. Turn TRIP ADJUST pot clockwise SLOWLY until CRITICAL SPEED LED stays on continuously.
4. Continue turning TRIP ADJUST pot clockwise until OUT OF RANGE LED begins to blink. ****
5. After RELAY STATUS LED is illuminated, return switch to RUN position.
6. A momentary TEST position is provided to simulate the loss of sensor signal which releases the control relay.
7. Repeat steps 1 thru 7 for remaining sensor adjustments.

**** Using the above calibration, the control relay will drop out at a machinery slow down of approximately 15%. For a 20% Margin, adjust the TRIP ADJUST control so that the OUT OF RANGE LED just comes on steady. For a 10% Margin, adjust the TRIP ADJUST control counterclockwise so that the OUT OF RANGE LED has just gone out. For ALL adjustments, the CRITICAL SPEED LED MUST stay on continuously. If a margin greater than 20% is desired, consult BWI EAGLE, INC.

NOTE: There is a "Safety Delay" built into the EAGLE 2 unit. This delay leaves the control relay un-energized for 5 seconds after critical speed has been achieved to prevent false machinery actuation during maintenance or assembly.



CONTROLS AND INDICATORS

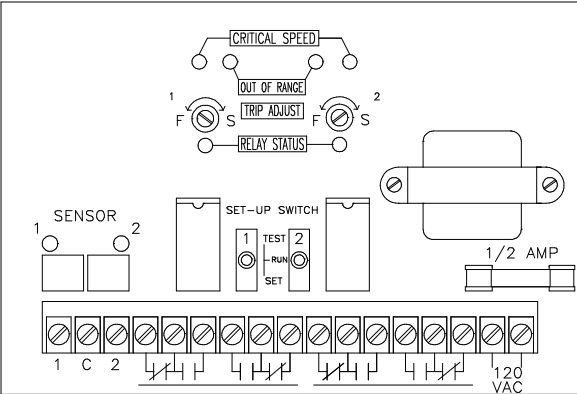

SPECIFICATIONS

AC Input	120 VAC 15 W
Fuse Protected	1 amp
Operating Temperature	-40°C to +60°C (-40° to +140°F)
Speed Range	60 - 800 RPM
Relay Contacts	DP/DT 8 amp @ 120 VAC
Safety Delay	5 Seconds
Response Time	1 Second or Less
Housing	NEMA 12 Standard

REPLACEMENT AND OPTIONAL PARTS

P.C. Board	11-7002
Variable Reluctance Sensor, General Mount	10-7003
Relay	99-REL-0001
Strain Relief (Power Input)	99-CON-0011
Strain Relief (Control)	99-CON-0012

EAGLE 2

Dual Channel Speed Switch

MODEL 11-7000

DIMENSIONS

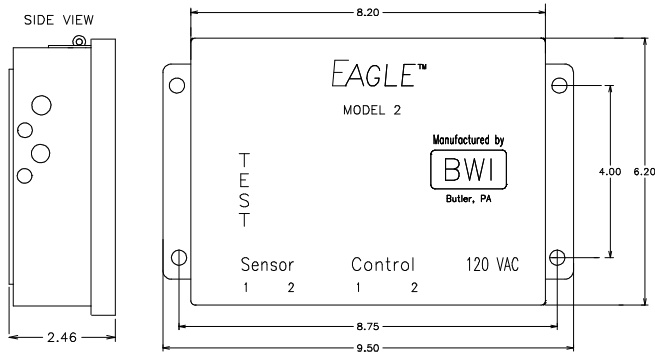

TYPICAL BELT STARTER

TYPICAL BELT STARTER
EAGLE 2 INSTALLATION

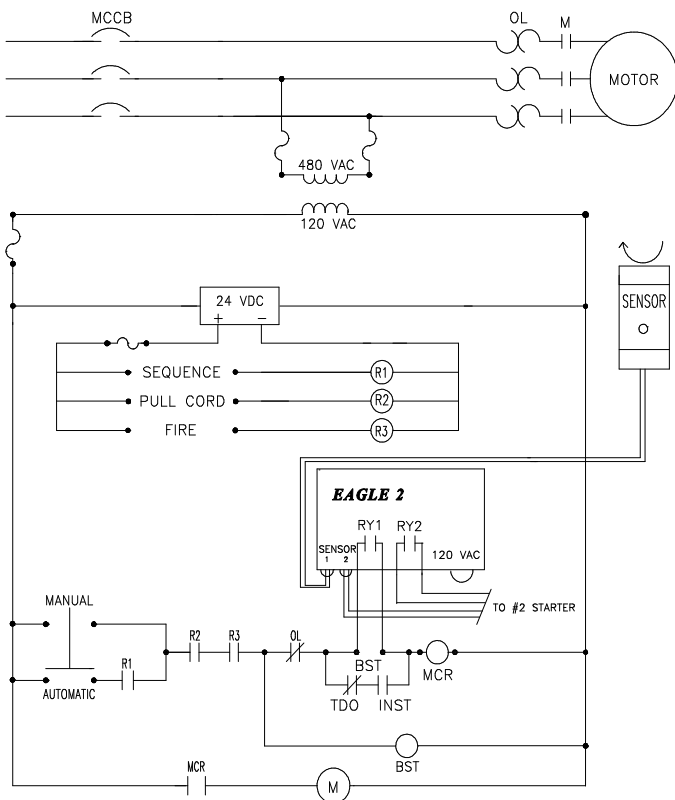

FIGURE 1

VR SENSOR

Variable Reluctance Type

MODELS 10-7003, 10-7032

INSTALLATION

1. Select the roller or shaft to be monitored. If a roller is to be monitored, be sure it is always contacting the belt.
2. Affix a target on the roller or shaft. Target should be a piece of key stock, 1/4-20 Hex Nut, etc. (Figure 1) Dents and notches are not recommended as targets.
3. Mount sensor firmly with hose clamps or U-bolts to prevent it from moving or working loose. Tape is **NOT** recommended as a fastener.
4. Before tightening, place sensor close enough to the target(s) to produce a strong, steady blinking on the sensor-head LED. The LED should blink in direct proportion to the roller speed. Effective distance between sensor and target(s) is approximately .25 inch to .75 inch depending on target mass and roller speed.

Figure 1

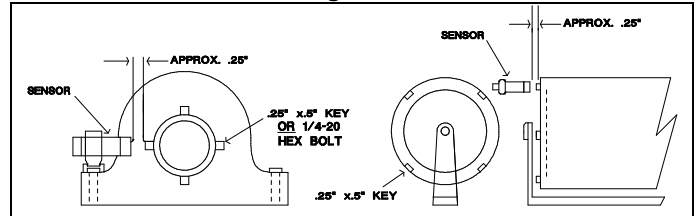

DIMENSIONS

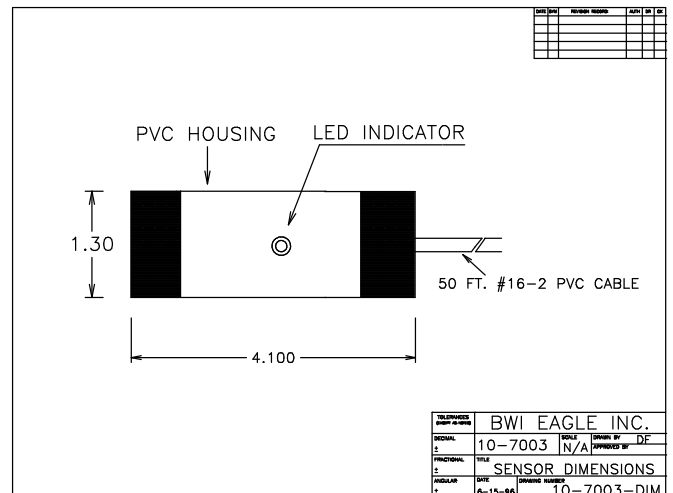

SPECIFICATIONS

Dimensions	4 in. x 1.3 in. O.D.
Sensor Type	Variable Reluctance Failsafe Output
Sensor Power Requirement	Current limited 12 VDC from Control Unit
Sensor Cable	Unshielded Twisted Pair 16/2
Distance	Sensor to control unit - 2 Miles MAX
Minimum Sensing Speed	60 RPM

BWI EAGLE INC.			
DESIGN	10-7003	DATE	DF
REV	N/A	APPROVED BY	
SENSOR DIMENSIONS			
DATE	6-15-86	DRAWING NUMBER	10-7003-DIM