

OPERATOR'S MANUAL

650408-X-B

INCLUDING: SPECIFICATIONS, SERVICE KITS, GENERAL INFORMATION, TROUBLESHOOTING.
 INCLUDE MANUALS: 65106-X Lower Pump End (pn 97999-578), 6544X-X Air Motor (pn 97999-64) & S-632 General Information Manual (pn 97999-624).

RELEASED: 02-24-88
REVISED: 10-18-11
(REV. G)

4-1/4" AIR MOTOR
9:1 RATIO
4" STROKE

650408-X-B TWO-BALL PUMP SERIES Stainless Steel



READ THIS MANUAL CAREFULLY BEFORE INSTALLING, OPERATING OR SERVICING THIS EQUIPMENT.

It is the responsibility of the employer to place this information in the hands of the operator. Keep for future reference.

SERVICE KITS

- Use only genuine ARO® replacement parts to assure compatible pressure rating and longest service life.
- **61268** for repair of air motor section.
- **637010** for repair of 65108 and 65108-5 lower pump ends.
- **637010-4** for repair of 65108-4 and 65108-6 lower pump ends.
- **637010-5** for repair of 65108-7 and 65108-9 lower pump ends.
- **637011** for replacement of lower ball check.

SPECIFICATIONS

Model Series (refer to option chart)	650408-X-B
Pump Type	Air Operated, Two-Ball
Ratio	9:1
Air Motor	
650408-B	65444-B
650408-2-B	65444-2-B
650408-4-B	65444-B
650408-5-B	65444-B
650408-6-B	65444-B
650408-7-B	65444-B
650408-8-B	65444-B
Motor Repair Kit	61268
Motor Diameter	4-1/4" (10.795 cm)
Stroke (double acting)	4" (10.16 cm)
Air Inlet (female)	1/2 - 14 N.P.T.F. - 1
Air Exhaust (female)	1-1/4 - 11-1/2 N.P.T.F. - 1
Lower Pump End Series	
650408-B	65108
650408-2-B	65108-4
650408-4-B	65108-4
650408-5-B	65108-5
650408-6-B	65108-6
650408-7-B	65108-7
650408-8-B	65108-9
Lower Pump Repair Kit	637010-X
Material Inlet (female)	1-1/4 - 11-1/2 N.P.S.M.
Material Outlet (female)	3/4 - 14 N.P.T.F. - 1

PERFORMANCE

Air Inlet Pressure Range	0 - 150 p.s.i. (0 - 10.3 bar)
Fluid Pressure Range	0 - 1350 p.s.i. (0 - 93.1 bar)
Maximum Rec'd Cycles / Minute	60
Displacement In³ Per Cycle	11.0
Volume / Cycle	6.1 oz. (180.2 ml)
Cycles Per Gallon	21
Flow @ 60 Cycles / Minute	2.9 g.p.m. (10.8 l.p.m)
Noise Level @ 60 p.s.i. - 40 c.p.m.	80 db(A)①
Accessories Available	66100 Wall Mount Bracket 91790 Silencer

PUMP DATA

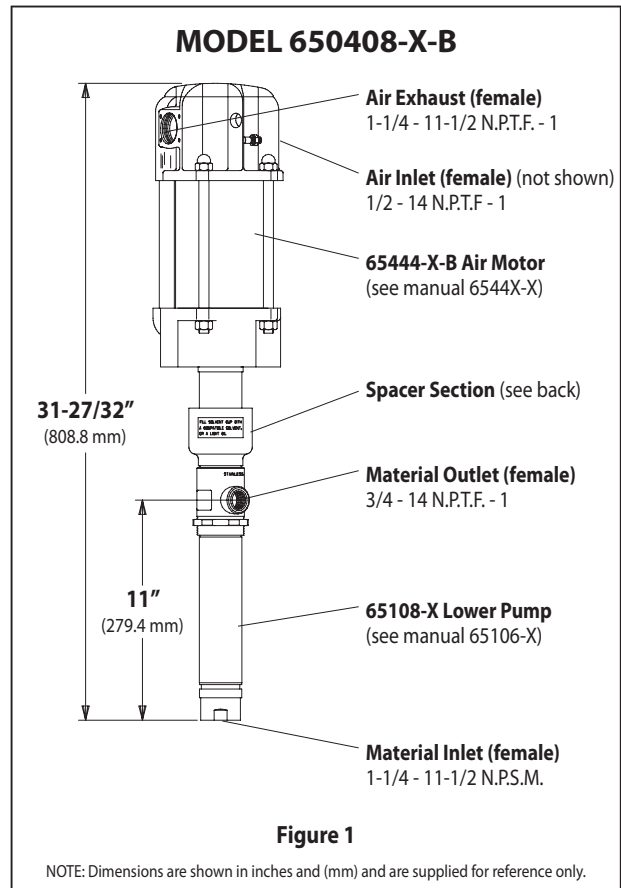

Figure 1

NOTE: Dimensions are shown in inches and (mm) and are supplied for reference only.

IMPORTANT

This is one of four documents which support the pump. Replacement copies of these forms are available upon request.

- 650408-X-B** Model Operator's Manual (pn 97999-22)
- S-632** General Information - Industrial Piston Pumps (pn 97999-624)
- 65106-X** Lower Pump End Operator's Manual (pn 97999-578)
- 6544X-X** Air Motor Operator's Manual (pn 97999-64)

① Tested with 91790 muffler assembly installed. The pump sound pressure level has updated to an Equivalent Continuous Sound Level (L_{AEG}) to meet the intent of ANSI S1.13-1971, CAGI-PNEUROPS 5.1 using four microphone locations.



PUMP OPTION DESCRIPTION CHART

650408 - X - B

DESCRIPTION

DESCRIPTION

- PTFE packing / Plain Rod & Tube, Standard Motor
- 2- UHMW-PE packing / Plain Rod & Tube, Counter Motor
- 4- UHMW-PE packing / Plain Rod & Tube, Standard Motor
- 5- PTFE packing / Ceramic Coated Rod & Tube, Standard Motor
- 6- UHMW-PE packing / Ceramic Coated Rod & Tube, Standard Motor
- 7- Viton® / UHMW-PE packing / Ceramic Coated Rod & Tube, Standard Motor
- 8- Viton / UHMW-PE packing / Plain Rod, Ceramic Coated Tube, Standard Motor

GENERAL DESCRIPTION

The two-ball design provides for easy priming of the lower foot valve. The double acting feature is standard in all ARO industrial pumps. Material is delivered to the pump discharge outlet on both the up and down stroke.

The motor is connected to the lower pump end with a spacer tube and solvent cup. This allows for lubrication of the upper packing gland and to prevent air motor contamination because of normal wear and eventual leakage through the material packing gland.

⚠️ WARNING HAZARDOUS PRESSURE. Do not exceed maximum operating pressure of 1,350 p.s.i. (93.1 bar) at 150 p.s.i. (10.3 bar) inlet air pressure.

Pump Ratio X Inlet Pressure to Pump Motor	=	Maximum Pump Fluid Pressure
--	---	--------------------------------

Pump ratio is an expression of the relationship between the pump motor area and the lower pump end area. EXAMPLE: When 150 p.s.i. (10.3 bar) inlet pressure is supplied to the motor of a 9:1 ratio pump, it will develop a maximum of 1,350 p.s.i. (93.1 bar) fluid pressure (at no flow) - as the fluid control is opened, the flow rate will increase as the motor cycle rate increases to keep up with the demand.

⚠️ WARNING Refer to general information sheet for additional safety precautions and important information.

NOTICE: Thermal expansion can occur when the fluid in the material lines is exposed to elevated temperatures. Example: Material lines located in a non-insulated roof area can warm due to sunlight. Install a pressure relief valve in the pumping system.

Replacement warning label (pn 92325) is available upon request.

TROUBLE SHOOTING

Pump problems can occur in either the air motor section or the lower pump end section. Use these basic guidelines to help determine which section is affected. Be sure to eliminate any possible non-pump problems before suspecting pump malfunction.

Pump will not cycle.

- No pressure to the motor. See motor manual.
- Restricted return lines. Clean obstruction.
- Damaged motor. Service the motor.

No material at the outlet (pump continually cycles).

- Check the material supply, disconnect or shut off the air supply and replenish the material, reconnect.

Material on one stroke only (fast downstroke).

- The lower check may not be seating in the foot valve (see lower pump disassembly). Remove the check from the foot valve, clean and inspect the valve seat area. If the check or foot valve are damaged, replace.

Material on one stroke only (fast upstroke).

- The middle packings may be worn (see lower pump disassembly). Replace the seals as necessary.

Material leakage out of the solvent cup or material appears on the pump plunger rod.

- Tighten the solvent cup until leakage discontinues. If this procedure does not aid in stopping the leakage problem, the upper packings may be worn (see lower pump disassembly). Replace the seals as necessary.

PUMP CONNECTION - UPPER / LOWER

NOTE: All threads are right hand.

1. Loosen (90606) lock nut and unscrew the entire pump from the air motor. This will expose (90609) retaining screw (see figure 2).
2. Unscrew (90609) retaining screw to remove pump assembly from the air motor.
3. Remove the (90608) shoulder nut to remove (90609) retaining screw.

PUMP CONNECTOR DETAIL

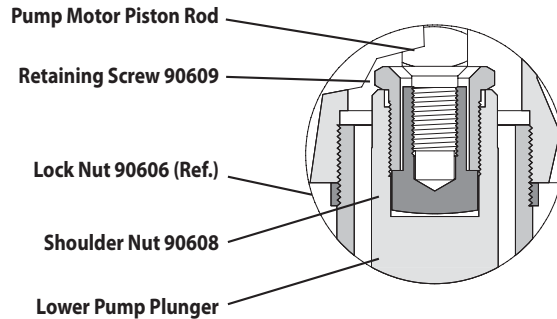

Figure 2

REASSEMBLY

1. Slide (90609) retaining screw over air motor rod (see figure 2).
2. Screw (90608) shoulder nut to air motor rod.
3. Apply Loctite® 242 to threads of (90609) retaining screw and screw (90609) retaining screw into lower pump plunger.
4. Screw the lower pump assembly to the air motor.
5. Position air motor exhaust port approximately 90° from lower pump outlet.
6. Screw (90606) lock nut against the air motor base and tighten to 50 - 65 ft. lbs (67.8 - 88.1 Nm).