

OPERATOR'S MANUAL

650839-X

SPECIFICATIONS, SERVICE KITS, GENERAL INFORMATION, TROUBLESHOOTING
INCLUDE MANUALS: 6720X-X LOWER PUMP END (PN 97999-788) &
S-632 GENERAL INFORMATION MANUAL (PN 97999-624)

RELEASED: 8-28-98
REVISED: 6-8-10
(REV. B)

8" AIR MOTOR
7:1 RATIO
6" STROKE

650839-X4X FOUR BALL PUMP SERIES 300 SERIES STAINLESS STEEL



**READ THIS MANUAL CAREFULLY BEFORE INSTALLING,
OPERATING OR SERVICING THIS EQUIPMENT.**

It is the responsibility of the employer to place this information in the hands of the operator. Keep for future reference.

SERVICE KITS

- Use only genuine ARO® replacement parts to assure compatible pressure rating and longest service life.
- **66614 for repair of Air Motor section.**
Service Note: The Air Motor Service / Parts Manual is not shipped with the pump but it is included with each service kit. If this Service / Parts Information is needed, request the Air Motor Operator's Manual from ARO (manual 66523, PN 97999-107).
- **637317-X4C for repair of Lower Pump section.**
Refer to the chart on page 2 for description of -X4X options.

SPECIFICATIONS

Model Series (Refer to option chart)	650839-X4X
Type	Air Operated, Four Ball
Ratio	7:1
Air Motor	66523
Motor Repair Kit	66614
Motor Diameter	8" (20.3 cm)
Stroke	6" (15.2 cm)
Air Inlet	3/4 - 14 N.P.T.F. - 1 (f)
Air Exhaust	1-1/4 - 11-1/2 N.P.T.F. - 1 (f)
Lower Pump End Series	67200-X4X
Lower Pump Repair Kit	637317-X4C
Material Inlet	1-1/2 - 11-1/2 N.P.T.F. - 1 (f) & 2 - 11-1/2 P.T.F. SAE Spec Short (m)
Material Outlet	1 - 11-1/2 N.P.T.F. - 1 (f)
Weight	94 lbs (42.6 kgs)

PERFORMANCE

Air Inlet Pressure Range	30 - 120 p.s.i. (2.1 - 8.3 bar)
Fluid Pressure Range	210 - 1009 p.s.i. (14.5 - 69.6 bar)
Max. Rec'd Cycles / Minute	60
Displacement In³ Per Cycle	77.5
Volume / Cycle	42.9 oz. (1269 ml)
Cycles Per Gallon	2.98
Flow @ 60 Cycles / Minute	20.1 g.p.m. (76.2 l.p.m.)
Noise Level @ 60 psi - 40 cpm	89.8 db(A) *

* The pump sound pressure level has been updated to an Equivalent Continuous Sound Level (L_{Aeq}) to meet the intent of ANSI S1. 13-1971, CAGI-PNEUROP S5.1 using four microphone locations.

PUMP DATA

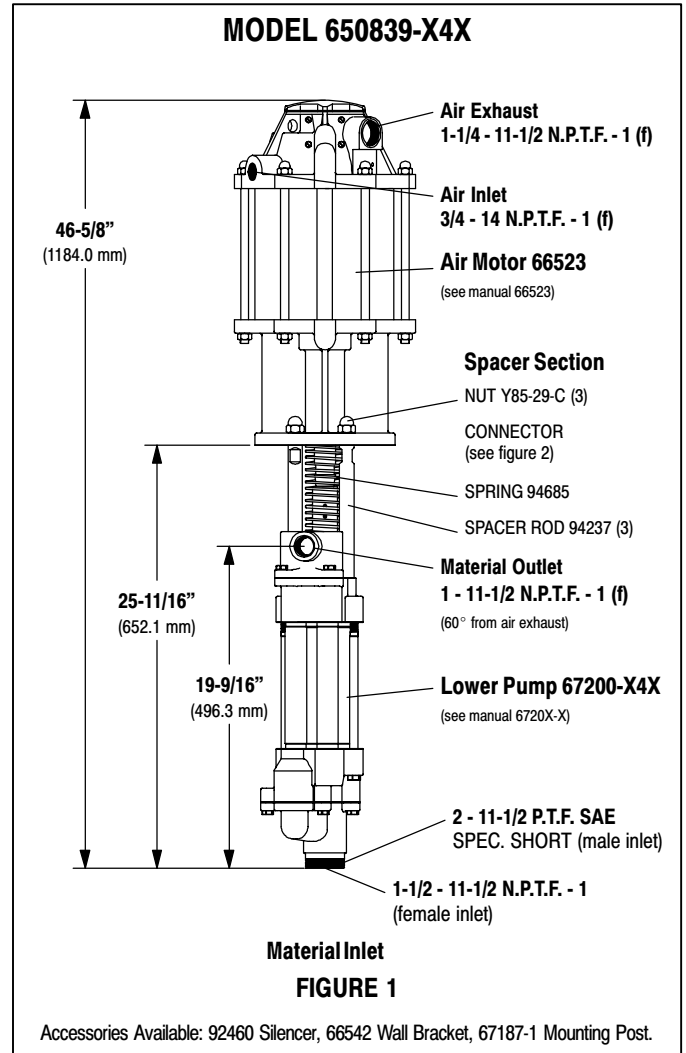

IMPORTANT

This is one of the four documents which support the pump. Replacement copies of these forms are available upon request.

- 650839-X MODEL OPERATOR'S MANUAL
- GENERAL INFORMATION - INDUSTRIAL PISTON PUMPS
- 6720X-X LOWER PUMP END OPERATOR'S MANUAL
- 66523 AIR MOTOR OPERATOR'S MANUAL

INGERSOLL RAND COMPANY LTD

209 NORTH MAIN STREET - BRYAN, OHIO 43506

☎ (800) 495-0276 • FAX(800) 892-6276

© 2010

www.ingersollrandproducts.com

ARO

IR Ingersoll Rand
Industrial Technologies

PUMP OPTION DESCRIPTION CHART

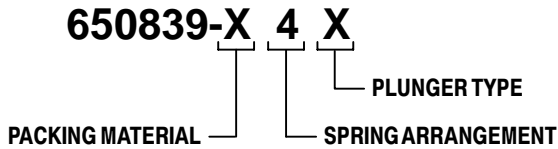

PACKING MATERIAL (PACKINGS ARE UPPER AND LOWER UNLESS NOTED)

7 Glass Filled PTFE (Upper) Virgin PTFE (Lower)	P UHMW-PE / PTFE Staggered (Upper) UHMW-PE (Lower)
C UHMW-PE	R PTFE / UHMW-PE Staggered (Upper) Virgin PTFE (Lower)
F UHMW-PE / Leather Staggered (Upper) UHMW-PE (Lower)	

SPRING ARRANGEMENT

4 Multiple Wave Spring

PLUNGER TYPE

7 HD SS W / Hard Chrome Plating (threaded)
 C HD SS W / Ceramic Coating (threaded)

GENERAL DESCRIPTION

⚠ WARNING HAZARDOUS PRESSURE. Do not exceed maximum operating pressure of 1009 p.s.i. (69.6 bar) at 120 p.s.i. (8.3 bar) inlet air pressure.

$$\frac{\text{PUMP RATIO X}}{\text{INLET PRESSURE TO PUMP MOTOR}} = \frac{\text{MAXIMUM PUMP FLUID PRESSURE}}{\text{PUMP MOTOR FLUID PRESSURE}}$$

Pump ratio is an expression of the relationship between the pump motor area and the lower pump end area. EXAMPLE: When 120 p.s.i. (8.3 bar) inlet pressure is supplied to the motor of a 7:1 ratio pump it will develop a maximum of 840 p.s.i. (57.9 bar) fluid pressure (at no flow) – as the fluid control is opened, the flow rate will increase as the motor cycle rate increases to keep up with the demand.

⚠ WARNING Refer to general information sheet for additional safety precautions and important information.

- The Four-Ball pumps are primarily designed for the high volume transfer of light and medium viscosity fluids. Stainless Steel construction offers compatibility with a wide range of fluids. The lower pump is designed for easy priming and the double acting feature is standard in all ARO industrial pumps. Material is delivered to the pump discharge outlet on both the up and down stroke.
- The motor is connected to the lower pump end by a spacer section. This allows for lubrication of the upper packing gland and prevents motor contamination because of normal wear and eventual leakage through the material packing gland. Be sure the solvent cup is adequately filled with lubricant to protect the upper packings and insure longest service life.

TROUBLE SHOOTING

Pump problems can occur in either the Air Motor Section or the Lower Pump End Section. Use these basic guidelines to help determine which section is affected.

If the pump will not cycle.

- Be certain to first check for non-pump problems including kinked, restrictive or plugged inlet / outlet hose or dispensing device. Depressurize the pump system and clean out any obstructions in the inlet / outlet material lines.
- Refer to the motor manual for trouble shooting if the pump does not cycle and / or air leaks from the air motor.

If the pump cycles but does not deliver material.

- Refer to the lower pump end manual for further trouble shooting.

PUMP CONNECTION – UPPER / LOWER

NOTE: All threads are right hand.

1. Lay the pump assembly on a workbench.
2. Remove the three nuts from the three spacer rods (figure 1).
3. Pull the air motor from the lower pump end until motor piston rod is in the “down” position and lower pump end rod is in “up” position.
4. Remove the cotter pins and unthread piston rods from the connector (figure 2).

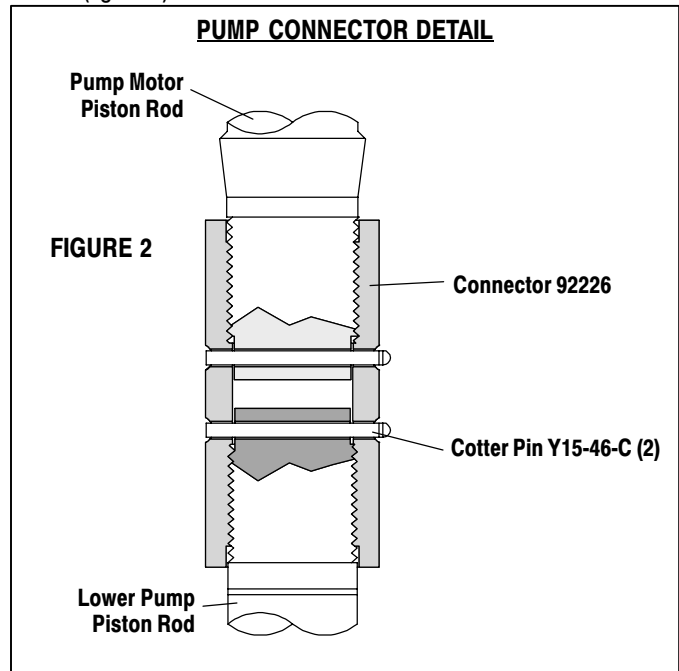

REASSEMBLY

1. Thread connector to pump motor piston rod until hole thru connector is aligned with hole thru piston rod.
2. Assemble cotter pin thru hole and bend ends of pin into groove of connector.
3. Thread connector to lower pump piston rod until hole thru connector is aligned with hole thru piston rod.
4. Assemble cotter pin thru hole and bend ends of pin into groove of connector. NOTE: Heads and ends of cotter pins must not extend more than .125” beyond o.d. of connector.
5. Reinstall the spacer rods to the pump motor.
6. Bring the motor and lower pump together and retain with the three nuts.