

HAUG Ionization - for the application of electrostatic charges



HAUG charging systems

HAUG charging systems are intended for the contact-free application of electrostatic charges. These systems are used wherever different materials need to be fixed to one another electrostatically. At least one of these materials must be insulating. This electrostatic fixation is intended to support downstream processes such as the film overlap in packaging machines.

Electrostatic charges are applied using charging bars or triodes which are supplied with positive or negative high voltage from a steplessly adjustable charging generator. In order to charge two-dimensional or partial areas, bar-shaped electrodes or triodes are used. A resistance-coupled version for special requirements is also available.

Applications

HAUG charging systems can be used, among others, in the following applications

- for fixing and positioning films and foils, paper and cardboard, e.g. on steel sheets, glass panels, wood panels or similar.
- in the production of CDs to reinforce adhesion
- for blocking film and paper stacks
- for IML technology

In order to ensure a continuous, reliable charging process, we strongly recommend discharging the materials to be bonded to each other using a suitable HAUG ionization system before charging.

A HAUG charging system consists of the following components:

- a charging generator with adjustable direct voltage output and
- one or more connected charging electrodes.

Generator AG 150 with ALS

The HAUG charging bar ALS is suitable for most applications where material webs are to be fixed to each other. The supply to the charging bar ALS is from the charging generator AG 150 which is available with either positive or negative polarity. The direct voltage output of the charging generator can be set steplessly, and a remote option is also available. The charging bar ALS must be fixed at a distance of some 10–30 mm above the material to be charged, directly opposite a suitable counter-electrode. The charging bar ALS is available both with an axial and a radial high-voltage cable connection. The high-voltage cable and the pin strip can be replaced easily.

iii.1

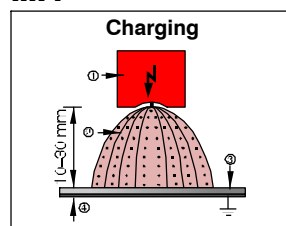

- ① Positive or negative voltage
- ② Electrical field
- ③ Insulator (e.g. film)
- ④ Counter-electrode (z.B. grounded metal plate)

AG 150



Generator TR 150 with ALT / ALM

HAUG charging triodes are characterized by a very homogenous field around the charging pins. Due to the special geometry of the charging triode, no spark-over to the counter-electrode can occur. The charging triode can therefore be mounted at a distance of approx. 10–30 mm from the material to be charged. The supply to the charging triodes is from the charging generator TR 150 which is available with either positive or negative polarity. The direct voltage output of the charging generator can be set steplessly, and a remote option is also available. The charging triode ensures a high charging performance even with very low direct voltage outputs and therefore ensures very good fixation. Due to its simple design incorporating magnetic clamps, the charging pins can be replaced very easily when worn. The charging triode is connected by means of a shielded high-voltage cable with plug-and-socket connector.

iii.2

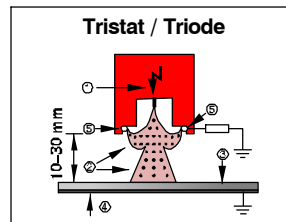

- ① Positive or negative voltage
- ② Electrical field
- ③ Insulator (e.g. film)
- ④ Counter-electrode (z.B. grounded metal plate)
- ⑤ Intake electrodes

TR 150



Generator HW 150 with ALW

The resistance-coupled charging electrode ALW is particularly recommended for applications where an increased risk of sparking exists which could lead to damage to high-grade surfaces or electronic components. The supply to the resistance-coupled charging electrode ALW is from the charging generator HW 150, which is available with either positive or negative polarity. The direct voltage output of the charging generator can be set steplessly, and a remote option is also available. Possible applications include situations where the counter-electrode required for charging is not always completely covered by the material to be charged, e.g. when two-dimensional material webs with varying widths are charged or when an uncovered gap between cut or separated materials is created on the substrate serving as counter-electrode.

iii.3

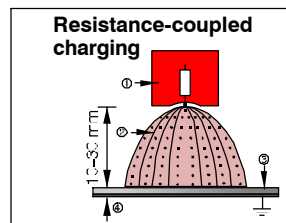

- ① Positive or negative voltage
- ② Electrical field
- ③ Insulator (e.g. film)
- ④ Counter-electrode (z.B. grounded metal plate)

HW 150



HAUG GmbH & Co. KG

Friedrich-List-Str. 18
D-70771 Leinf.-Echterdingen
Phone: +49 711 / 94 98-0
Telefax: +49 711 / 94 98-298

Germany

www.haug.de
E-mail: info@haug.de

HAUG Biel AG

Johann-Renfer-Str. 60
CH-2500 Biel-Bienne 6
Phone: +41 32 / 344 96 96
Telefax: +41 32 / 344 96 97

Switzerland

www.haug-ionisation.com
E-mail: info@haug-biel.ch





AG 1 50 / TR 1 50 / HW 1 50

Technical data AG / TR / HW 150

Dimensions (W x H x D):	270 x 170 x 150
Protection type:	IP 54
Protection class:	I
Supply voltage:	230 V _~ / 115 V _~ (50 – 60 Hz)
High-voltage terminals:	1 (AG)
Power input:	approx. 30 VA
Output voltage:	$U_{max.} = 15 \text{ kV} \pm 10\%$
Output current:	$I_{max.} = 300 \mu\text{A} \pm 15\%$
Signalingcontacts monitoring:	Contactrating max. 24 V _{AC} / 35 V _{DC} , max. 50 mA
Pulse frequency via pluse input:	max. 1 Hz (max. 10 ⁶ cycles)
Recovery time after overloadswitch-off:	< 10 s
Operating temperature:	+5 °C to +45 °C
Storage/transporttemperature:	-15 °C to +60 °C
Weight:	7kg
Mains cable:	2.6 m, fixed to the device

Subject to technical changes!

Variants

	Digital display	Overcurrent	Remotecontrol	Pulsing	Reset	Monitor output
A	Voltage and current	Switch-off	none	Floating normally open contact	Floating normally open contact	0 – 10 V
S	none	Switch-off	0 – 10 V	24 V _{DC}	24 V _{DC}	0 – 10 V
P	none	Switch-off	4 – 20 mA	Floating normally open contact	Floating normally open contact	4 – 20 mA

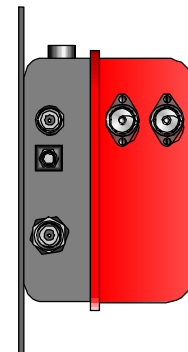
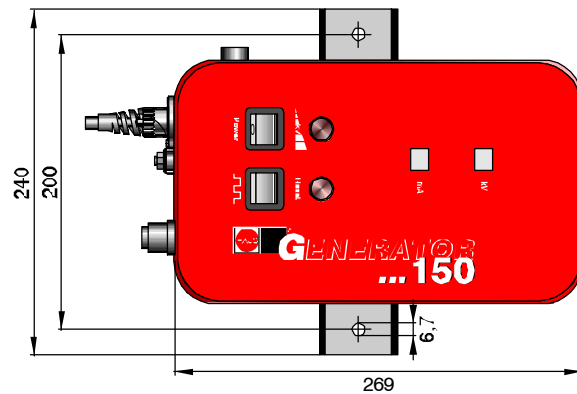
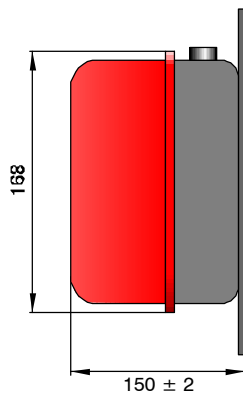

Variant A

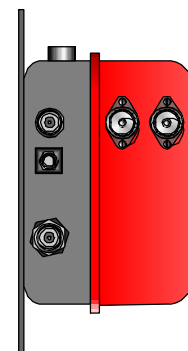
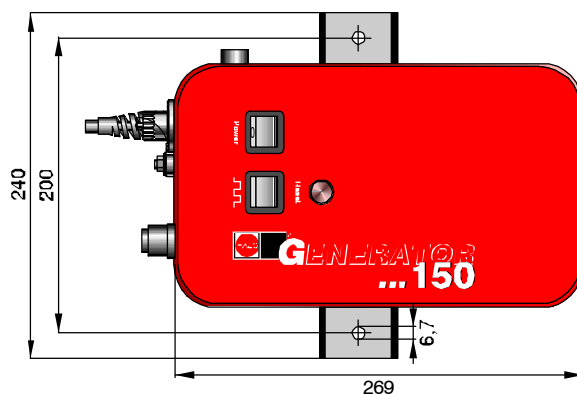
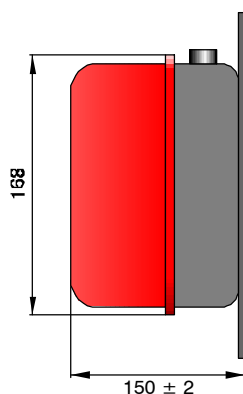

Variants S/P