

W A L C H E M

An Iwaki America Company

Active Electrodeless Sensors

ACTIVE ELECTRODELESS SENSORS

Instruction Manual

Five Boynton Road Hopping Brook Park Holliston, MA 01746 USA

TEL: 508-429-1110 FAX: 508-429-7433 WEB: www.walchem.com

Notice

© 2008 WALCHEM, An Iwaki America Incorporated Company (hereinafter "Walchem")
5 Boynton Road, Holliston, MA 01746 USA
(508) 429-1110
All Rights Reserved
Printed in USA

Proprietary Material

The information and descriptions contained herein are the property of WALCHEM. Such information and descriptions may not be copied or reproduced by any means, or disseminated or distributed without the express prior written permission of WALCHEM, 5 Boynton Road, Holliston, MA 01746.

This document is for information purposes only and is subject to change without notice.

Statement of Limited Warranty

WALCHEM warrants equipment of its manufacture, and bearing its identification to be free from defects in workmanship and material for a period of 24 months for electronics and 12 months for mechanical parts and electrodes from date of delivery from the factory or authorized distributor under normal use and service and otherwise when such equipment is used in accordance with instructions furnished by WALCHEM and for the purposes disclosed in writing at the time of purchase, if any. WALCHEM's liability under this warranty shall be limited to replacement or repair, F.O.B. Holliston, MA U.S.A. of any defective equipment or part which, having been returned to WALCHEM, transportation charges prepaid, has been inspected and determined by WALCHEM to be defective. Replaceable elastomeric parts and glass components are expendable and are not covered by any warranty.

THIS WARRANTY IS IN LIEU OF ANY OTHER WARRANTY, EITHER EXPRESS OR IMPLIED, AS TO DESCRIPTION, QUALITY, MERCHANTABILITY, FITNESS FOR ANY PARTICULAR PURPOSE OR USE, OR ANY OTHER MATTER.

180391.A
Oct 2008

Table of Contents

1.0	Introduction	4
2.0	Specifications	4
2.1	Measurement Performance	4
2.2	Mechanical	4
3.0	Unpacking and Installation	5
3.1	Unpacking the unit	5
3.2	Mechanical Installation	5
3.3	Electrical Installation	10
4.0	Maintenance	11
4.1	Cleaning the sensor	11
5.0	Troubleshooting	15

1.0 Introduction

The electrodeless conductivity sensors measure an induced current in a loop submerged in solution. Two coils are enclosed within the sensor, which is immersed in the chemical whose conductivity is of interest. An AC signal applied to one of the coils induces a current in the other coil, which is directly proportional to the conductivity of the solution. An active preamplifier in the sensor, specific for a given range of conductivity, converts this signal to a millivolt signal that can be read by WebMaster and WEC400 series controllers.

2.0 Specifications

2.1 Measurement Performance

Conductivity Ranges:	100–1000 $\mu\text{S}/\text{cm}$, 1000–10,000 $\mu\text{S}/\text{cm}$, 10–100 mS/cm , 100–1000 mS/cm
Conductivity Resolution:	1 $\mu\text{S}/\text{cm}$, 1 $\mu\text{S}/\text{cm}$, 0.1 mS/cm , 1 mS/cm
Conductivity Accuracy:	$\pm 1\%$ of Span within the specified range
Temperature Range:	-5 to 80 °C, 20 to 180 °F (CPVC) -5 to 120 °C, 20 to 190 °F (PEEK)
Temperature Resolution:	1 ° (C or F)
Temperature Accuracy:	$\pm 1\%$ of Reading

2.2 Mechanical

Sensor Material:	CPVC	PEEK
O-Ring Material:	FKM (in-line only)	N/A
Mounting Adapter Material:	CPVC (in-line only)	316 SS (in-line only)
Dimensions:	7" long x 1.75" diameter	7" long x 1.75" diameter
Sensing Coil:	0.5 (1.3cm) aperture	0.5 (1.3cm) aperture
Temperature Limitations:	+20 to 180°F (-5 to 80°C)	+20 to 190°F (-5 to 88°C)
Pressure Rating:	-15 to +140 psi (-0.1 to 0.98 MPa)	-15 to +250 psi (-0.1 to 1.75 MPa)
Mounting:		
Submersion	1" NPTM thread	1" NPTM thread
In-Line	2" NPTM adapter	2" NPTM adapter

3.0 Unpacking and Installation

3.1 Unpacking the unit

Inspect the contents of the carton. Please notify the carrier if there are any signs of damage to the sensor or its parts. Contact your distributor if any of the parts are missing. The carton should contain a PEEK (brown) or CPVC (gray) sensor assembly and instruction manual. Any options or accessories will be incorporated as ordered.

3.2 Mechanical Installation

General Guidelines

- Mount the sensor as close as possible to the controller.
- Use only Walchem extension cable if 20 feet of cable is not sufficient.
- Take care to shield the cable properly.
- Maximum cable length is 250 feet.
- Position the sensor such that a fresh, representative sample of the solution is available.
- Position the sensor such that air bubbles will not be trapped within the sensing area.
- Position the sensor where sediment or oil will not accumulate within the sensing area.
- If cable is installed in metal conduit (recommended), either flexible conduit should be used or some other provision made for removal of sensor from the process for maintenance.

Note: There are two notches at the cable cap that line up with the hole through the sensor. These notches are an aid in positioning the sensor in a pipe or vessel. The user should direct the flow through the sensor bore.

Submersion Installations

The submersion sensor requires a standard 1" NPTF coupling (user supplied) for connection to standard compatible pipe. The sensor should be immersed away from the walls and floor of the tank by a minimum of 2 inches. The support pipe must be long enough to be above solution level. It should be sealed at the top, with a user supplied cable clamp, to prevent moisture from filling the pipe. See Figure 3. This pipe will usually be suspended from a bracket attached to the lip of the tank.

If the cable run will be exposed to moisture (rain, hosing, etc.), it must be protected with flexible conduit (preferably metal).

In-Line Installations

Thread the custom bushing into the end port of a 2" or larger diameter tee as shown in Figure 4A. Note that the top of the sensor has a dimple drilled in the side to indicate the direction of the flow channel. Align this dimple with the tee exit. 2" to ¾" adapters are usually used on the entry and exit ports to allow the use of ¾" pipe.

Caution: *It is important that the flow direction is in the end port and out the side port (as shown in Figure 4A) to provide maximum cleaning of the sensor.*

Insert the sensor cable up through the custom lock nut as shown in Figure 4A. Lubricate the o-ring and insert the sensor into the custom bushing. The flange on the sensor provides a sealing surface against the o-ring.

If the sensor will be exposed to moisture (rain, hosing, etc.) the cable end must be protected.

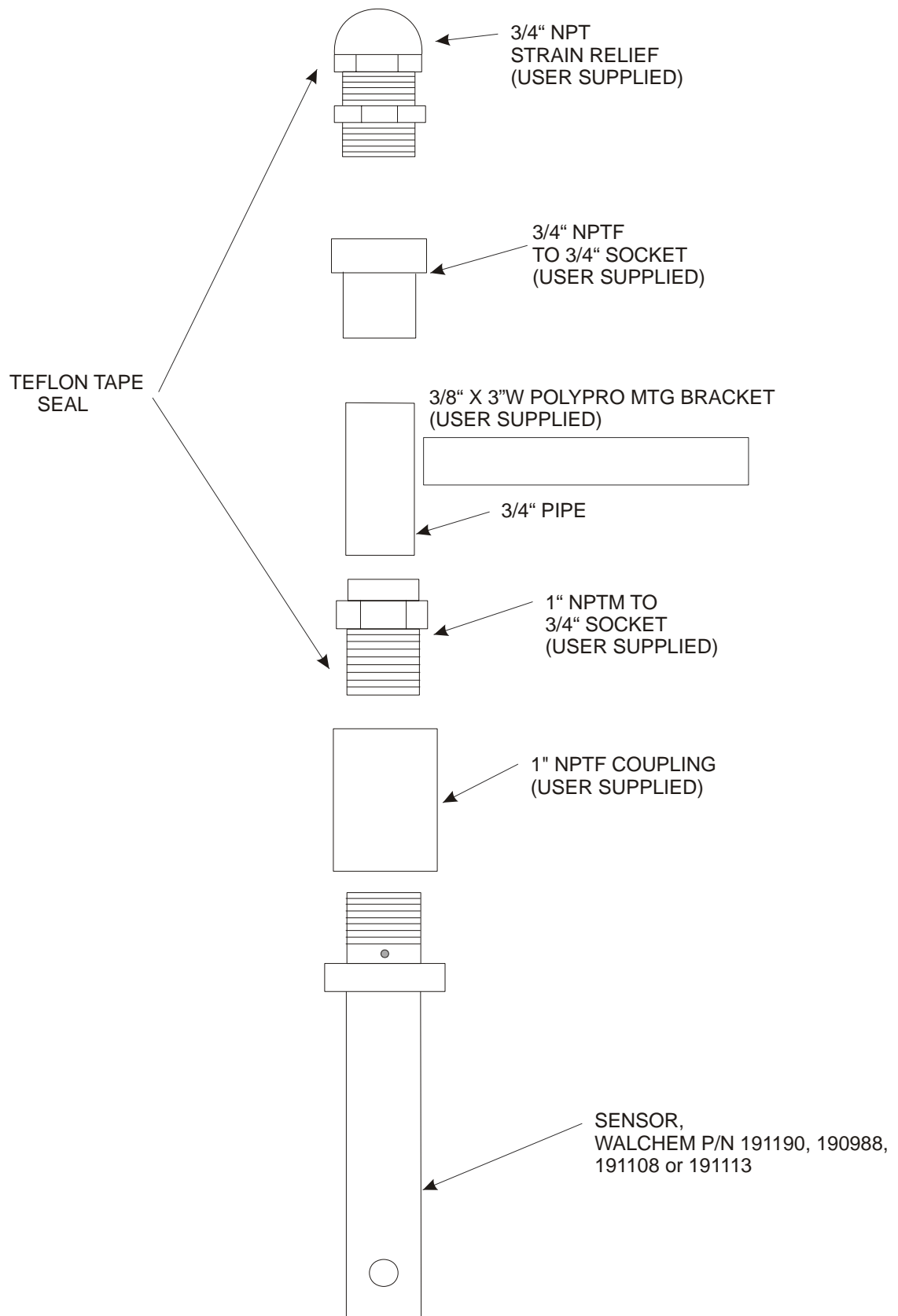

Figure 3 – Submersion Installation

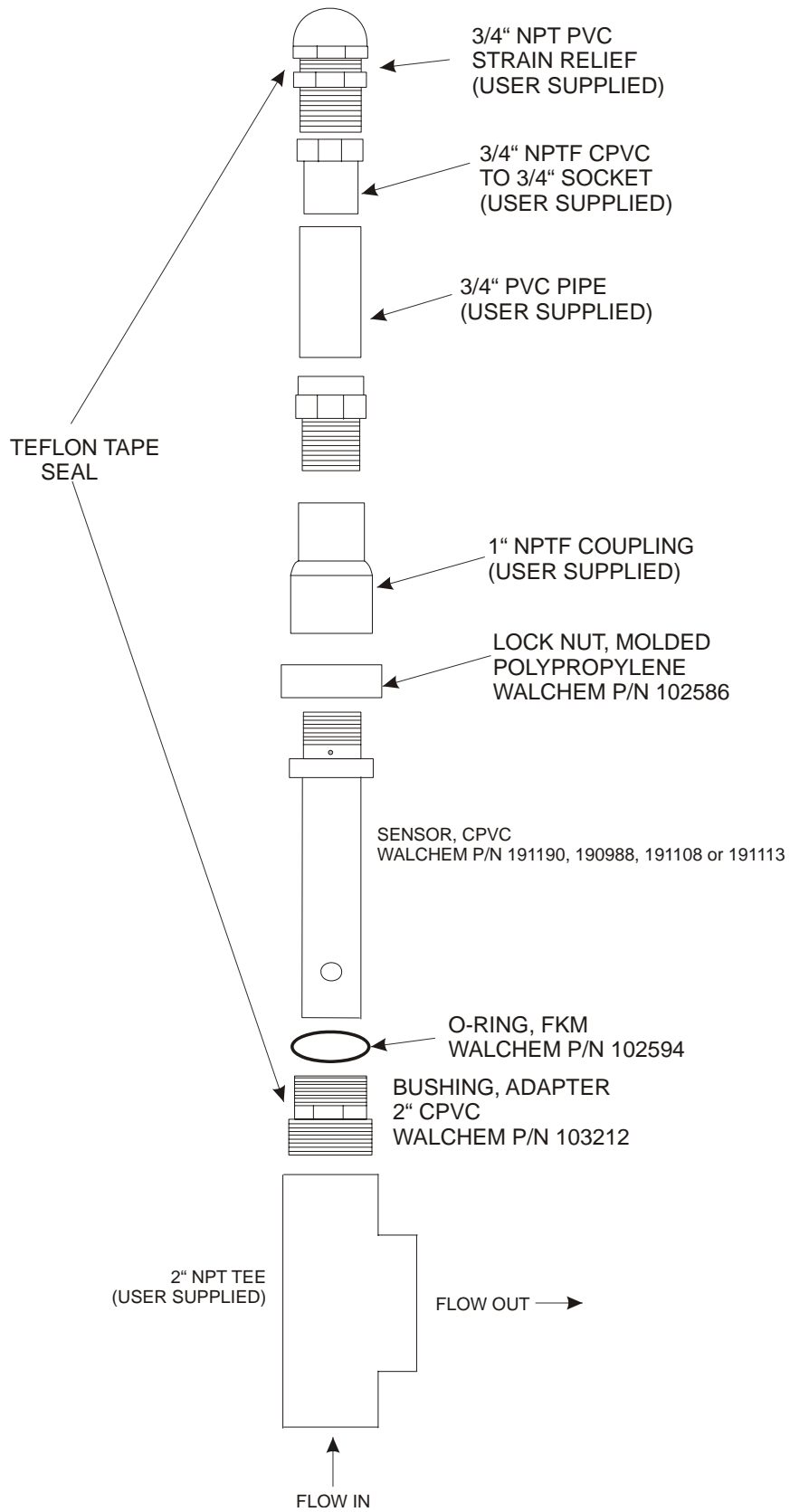

Figure 4A In-Line Installation – CPVC

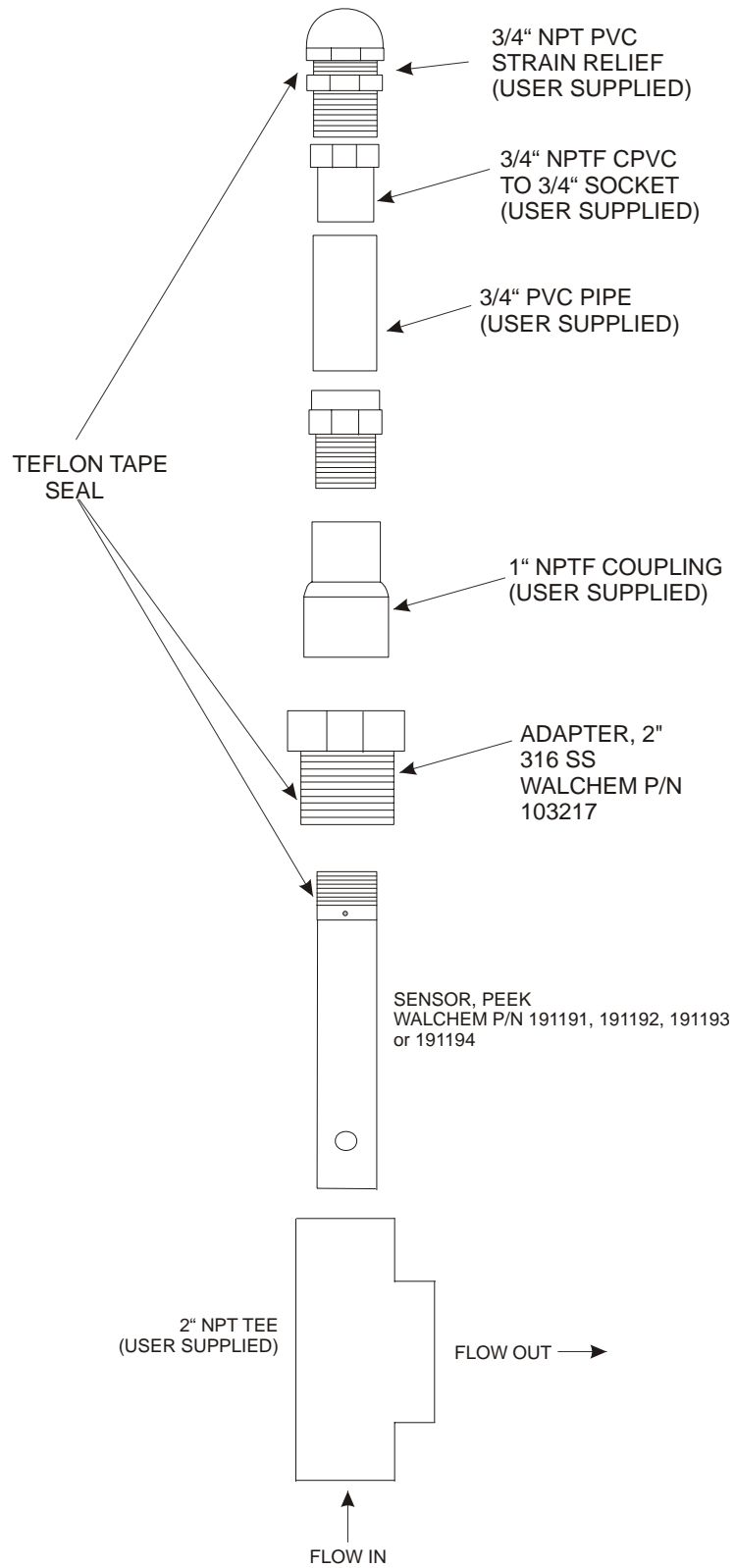

Figure 4B In-Line Installation – PEEK

3.3 Electrical Installation

Route the cable through one of the watertight cable glands on the controller, and connect the wires according to the color code shown in figure 7. For cable lengths beyond the standard 20 feet, a junction box (p/n 190851) and extension cable (p/n 102535) must be used.

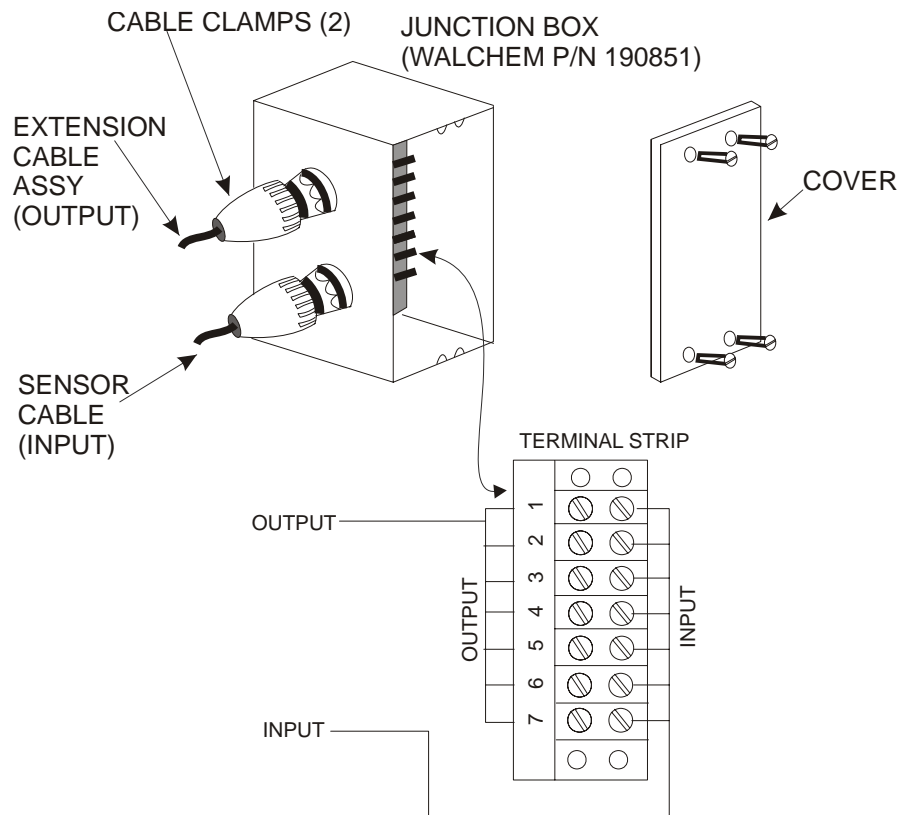

Figure 5 Junction Box Wiring

Mechanical mounting of the Junction Box

Open the junction box enclosure and use the two holes to screw the enclosure in place (mounting screws are user supplied). See Figure 6 for dimensions. Place the junction box within 20 feet of the sensor, in an area that is protected from excessive fumes or moisture. Locate the cable entry on the bottom to minimize leakage problems.

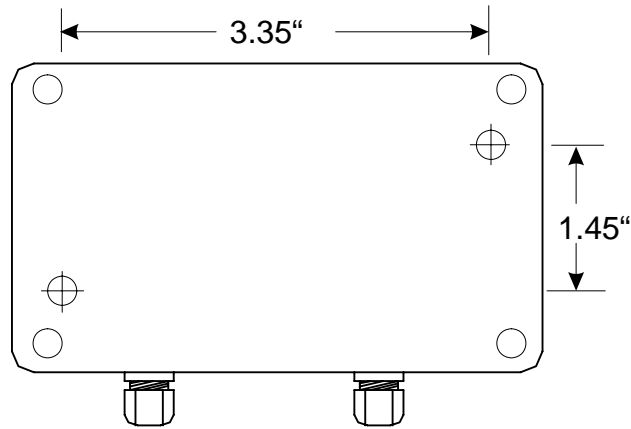

Figure 6 Junction Box Mounting Dimensions

Electrical installation of the Junction Box

Route the sensor cable through the watertight cable gland and attach the wires to the terminal strip inside the junction box according to the color codes shown in figure 5. Attach the extension cable to the controller terminal strip according to the color codes shown in figure 7.

4.0 Maintenance

4.1 Cleaning the sensor

Note: the controller must be recalibrated after cleaning the sensor.

- The sensor should be cleaned periodically. The frequency required will vary by installation. In a new installation, it is recommended that the sensor be cleaned after two weeks of service. To determine how often the sensor must be cleaned, follow the procedure below:
 1. Read and record the conductivity.
 2. Remove, clean and replace the conductivity sensor.
 3. Read conductivity and compare with the reading in step 1 above.

- If the variance in readings is greater than 5%, increase the frequency of sensor cleaning. If there is less than 1% change in the reading, the sensor was not dirty and can be cleaned less often.

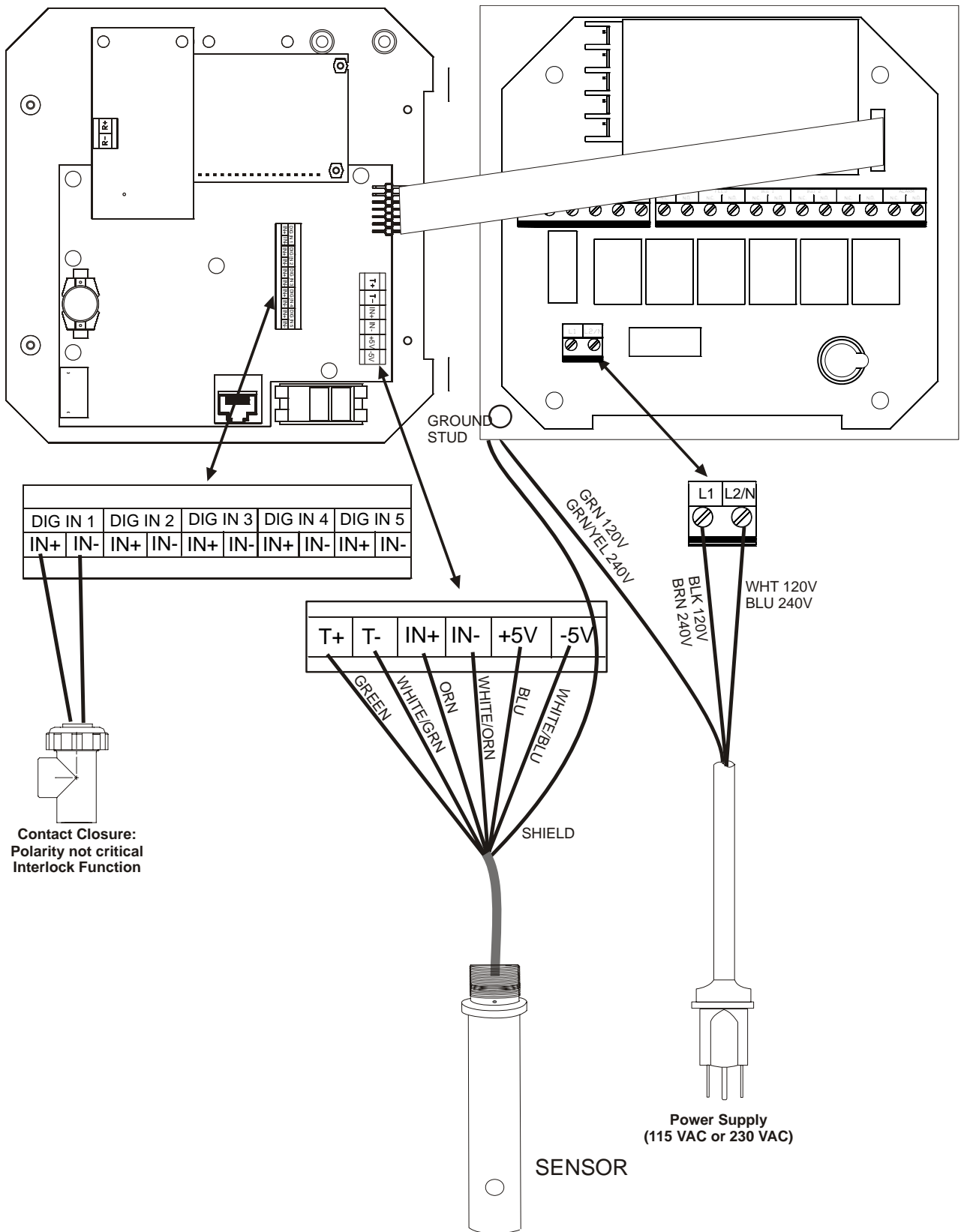

Figure 7a WEC Input Wiring

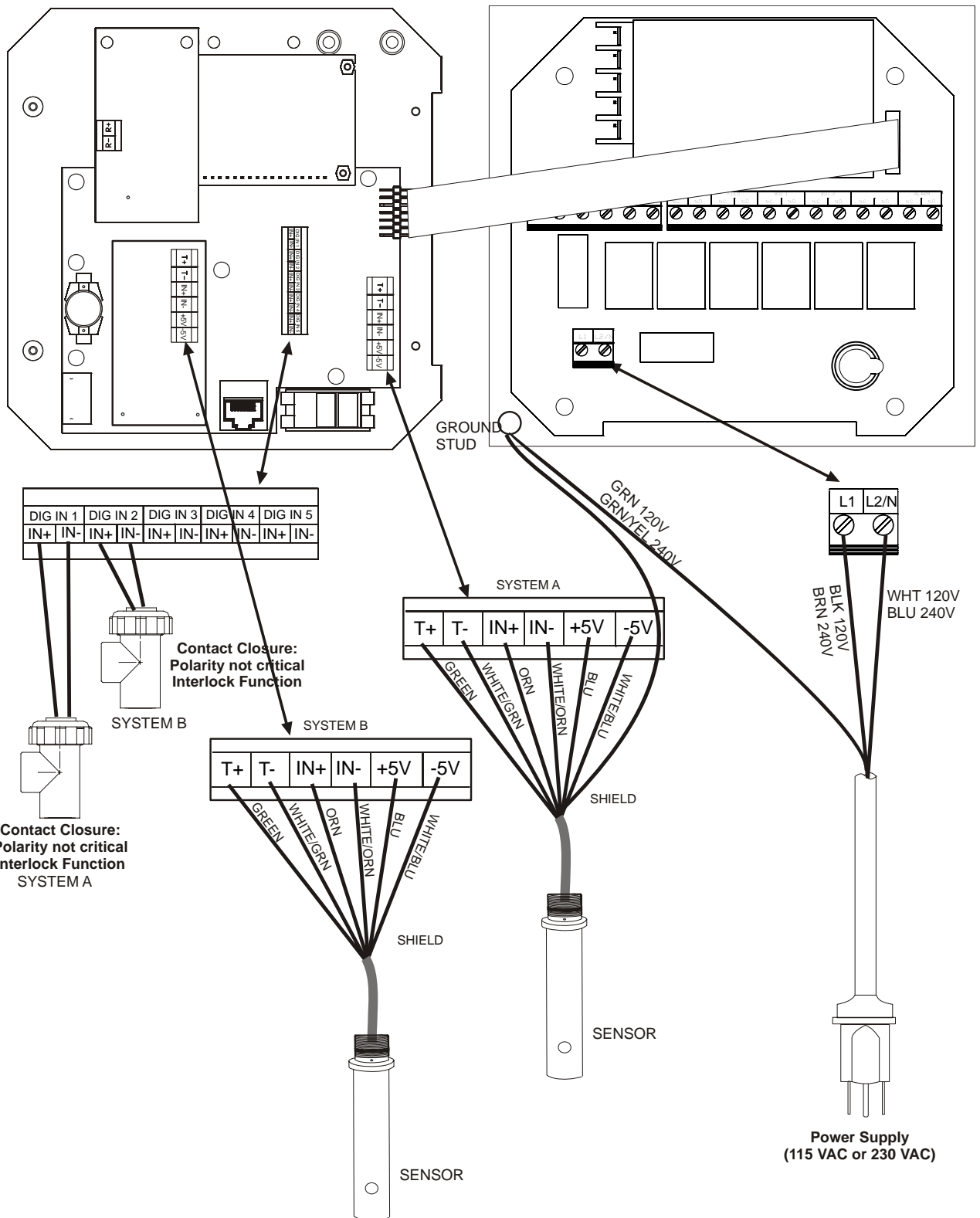
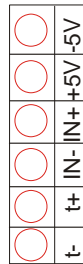
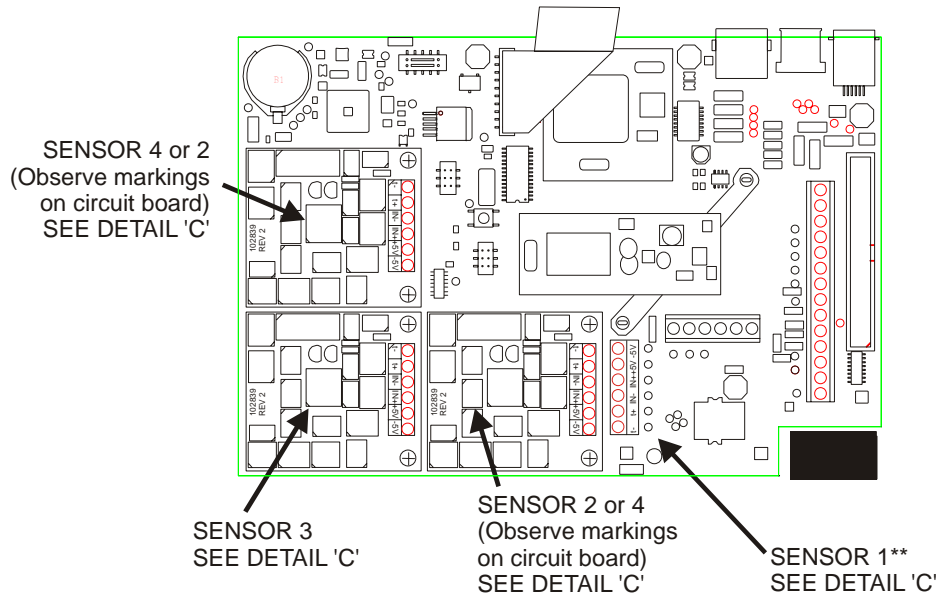
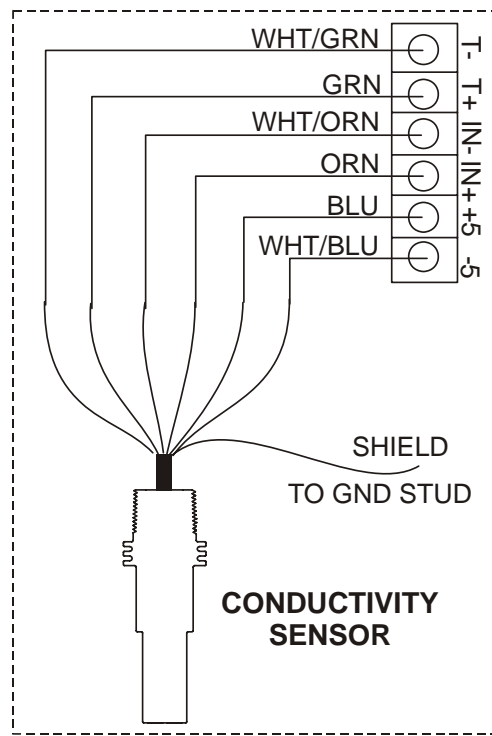

Figure 7b WDEC Input Wiring



Sensor 1
Terminal
Block

** Please note: Sensor 1 terminal
block is oriented OPPOSITE of
sensors 2-4.



SENSOR DETAIL "C"

Figure 7c WebMaster Inputs

Cleaning Procedure

An accumulation of dirt or debris on the sensor can affect the accuracy and the thermal time constant. This accumulation should be removed periodically. This can be accomplished by scrubbing with a toothbrush or stiff bottle brush. Soap or hand cleaner may help. Harsh abrasives should be avoided. Rinse the sensor thoroughly before returning to service.

Degaussing the sensor

Occasionally, when operating at low conductance (100-500 μ S), a sensor may become magnetized. This might happen during maintenance or calibration, if the sensor is placed near a large transformer or high magnetic field of a motor. Magnetization of the sensor may result in erratic behavior or unexplained positive or negative offsets.

To degauss a sensor, use a degaussing tool such as that used for erasing magnetic tape heads. With degaussing tool power on, bring the tool close to the sensor and move the tool slowly around the sensor in close proximity. Then slowly move the tool away from the sensor. Turn tool power off. This should be done with the controller power off.

5.0 Troubleshooting

To find out if the sensor or the controller is faulty, select the Self-Test menu, as described in the controller manual. If the problem is internal, an error message will appear on the lower line of the display. Call Walchem customer service.

If the Self-Test passes proceed as described below.

- To check the sensor, check the sensor electrical connections to the terminal strip (refer to Figure 6). Make sure that the correct colors go to the correct terminals and the connections are tight. Restore power and see if the conductivity is back to normal.
- Using a voltmeter, measure the +5 VDC versus IN-, and -5 VDC versus IN- to ensure that the preamplifier is getting power. If an extension cable is used, measure at the controller and the junction box.
- If the sensor is getting power, measure VDC between IN+ and IN-. If this is outside of the range of -300 mV to + 1000 mV, the connections or the sensor is faulty. . If an extension cable is used, measure at the controller and the junction box.
- Interference
The principle of operation involves a drive coil inducing a current in a receive coil. The liquid being tested is the coupling media. Calibration factors are determined when the coils are completely surrounded by this liquid. Should anything interfere with this coupling (i.e. buildup on the sensor, bubbles on the sensor, close proximity to the tank wall, any submerged object like a tumbling barrel), the reading will be distorted.

If the interference is a conductive object, it will increase the reading. If the interference is a non-conductive object, (which displaces the liquid from the sensor), it will reduce the reading. Keep these principles in mind when placing the sensor as well as when troubleshooting.