



238 Pillow Street
Butler, PA 16001
724-283-4681
724-283-5939 (fax)
www.bwieagle.com

PRODUCT INFORMATION BULLETIN

OPTIMA 2 Dual Channel Critical Speed Switch MODEL 11-7100ALS SERIES

DESCRIPTION

The OPTIMA 2 11-7100ALS models are a series of low speed switches that monitor speed and detect motion to as slow as 6 RPM in all types of machinery and apparatus. The OPTIMA 2 utilizes a non-contacting proximity sensor that may be remotely located up to two miles from the control unit. Its rugged NEMA enclosure, with up-front display, is well-suited to meet the environmental challenges of any industry. Ideal for conveyors, crushers, fans, motors and other rotating apparatus.

INSTALLATION

Disconnect AC power before proceeding with installation

1. Make the following connections:
 - A. Connect power cable to 120 VAC.
 - B. Connect control cables to appropriate terminals in the motor control circuit. (See TYPICAL BELT STARTER)
 - C. Connect the EAGLE PROX SENSORS to the connectors on the OPTIMA control unit.
2. Install sensors at roller or shaft. See sensor installation sheet.

SETUP AND TESTING

Final calibration should be performed with the belt loaded and running at normal speed.

1. Turn SPEED 1 control CCW until it stops. (Approximately 7 o'clock)
2. Hold TEST/SET switch (SW1) in the SET position to energize relay (RY1).
3. Turn SPEED 1 control CW SLOWLY, until CRITICAL LED (LED 3) stays on continuously.
4. Continue turning SPEED 1 control until MARGIN LED (LED 4) stays on continuously.
5. Turn SPEED control CCW until MARGIN LED (LED 4) begins to blink at the same rate as the SENSOR LED.
6. After the RELAY STATUS LED (LED 1) is illuminated, return the TEST/SET switch (SW1) to the RUN (center) position.
7. A momentary TEST position is provided to simulate the loss of sensor signal which releases the control relay.
8. Repeat steps 1 through 7 for calibration of Channel 2.



CONTROLS AND INDICATORS

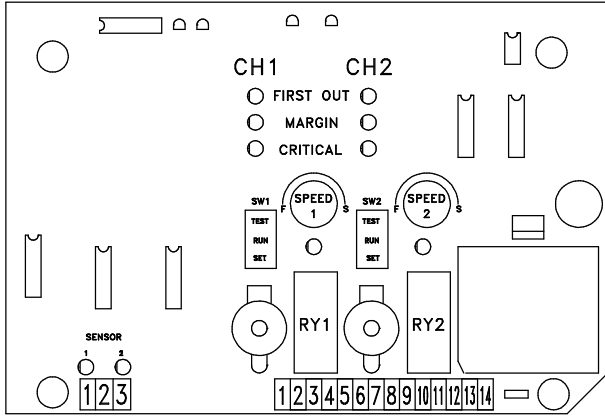

TERMINAL STRIP WIRING

The OPTIMA unit is shipped with the control cables installed on the normally open contacts. The control cables should be installed directly in the series circuit driving the motor control relay. (See TYPICAL BELT STARTER) The additional contacts supplied on the printed circuit card can be used, but the First-Out capability is only installed on the one set of normally open contacts per channel.

CHANNEL 1		CHANNEL 2		120 VAC	
1	N/C	7	N/C	13	120 VAC
2	C (1 ST OUT)	8	C (1 ST OUT)	14	120VAC
3	N/O (1 ST OUT)	9	N/O (1 ST OUT)		
4	N/O	10	N/O		
5	C	11	C		
6	N/C	12	N/C		

OPTIMA 2

Dual Channel Critical Speed Switch

MODEL 11-7100ALS SERIES

FIRST OUT OPERATION

The EAGLE OPTIMA "First Out" capability enables the user to visually see (by an LED indicator) if the slip switch relay contacts were the first to open. Once the belt is running and the control relay in the OPTIMA unit has energized, the First-Out indication (if activated) will extinguish. If the belt begins to slip and the OPTIMA unit shuts the drive down, the First-Out LED will illuminate. This LED will stay lit until the belt is restarted and the control relay in the Optima has energized. If R1, R2, or R3 (See TYPICAL BELT STARTER) would open, this would shut the drive down and also the slip switch contacts would open. But, the First-Out LED would not be illuminated. This would allow the user to see that the slip switch relay contacts were not the first to open and cause the shutdown.

FRONT COVER INDICATORS

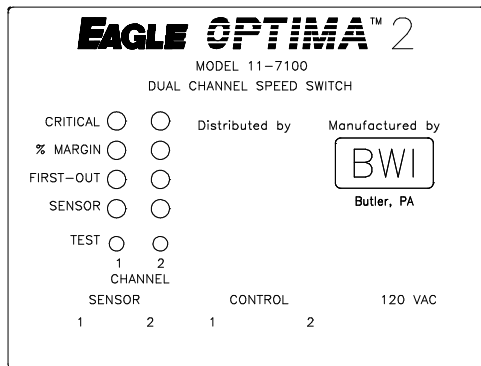

CRITICAL SPEED LED - Must be illuminated continuously to allow control relay to energize.

MARGIN LED - Indicates the percentage of slip the user has calibrated the unit for: (Out = 10%, Blinking = 15%, Solid = 20%)

FIRST-OUT LED - When illuminated, indicates that the OPTIMA unit has caused the shutdown.

SENSOR LED - Pulses at the rate of speed being received by the sensor.

TEST SWITCH - When pushed, simulates a loss of sensor signal which will drop out the control relay.

SPECIFICATIONS

AC Input	120 VAC 15 W
Fuse Protected	2 amp
Speed Range - ALS-6	6 - 60 RPM
ALS-15	15 - 100 RPM
ALS-25	25 - 200 RPM
Relay Contacts	DPDT 8 amp @ 120 VAC per channel
First-Out Current Range	17mA - 8 amps
Safety Delay	5 Seconds
Response Time	1 Second or Less
Enclosure	NEMA 12 Standard

DIMENSIONS

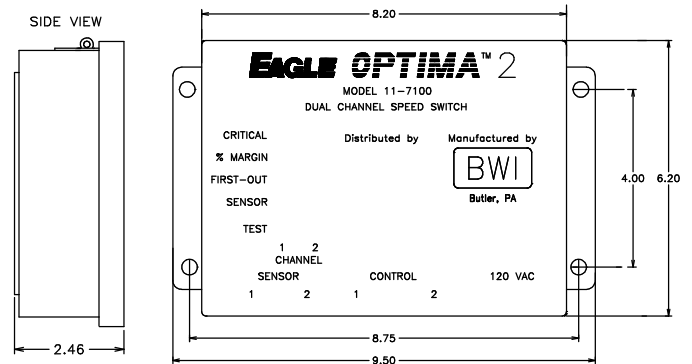

REPLACEMENT AND OPTIONAL PARTS

DESCRIPTION	PART NO.
P.C. Board	11-7102ALS-6, 15 or 25
Proximity Sensor, General Mount	10-7135
Relay	99-REL-0001
Strain Relief (Power Input)	99-CON-0011
Strain Relief (Control)	99-CON-0012

TYPICAL BELT STARTER

TYPICAL BELT STARTER
EAGLE OPTIMA 2 INSTALLATION

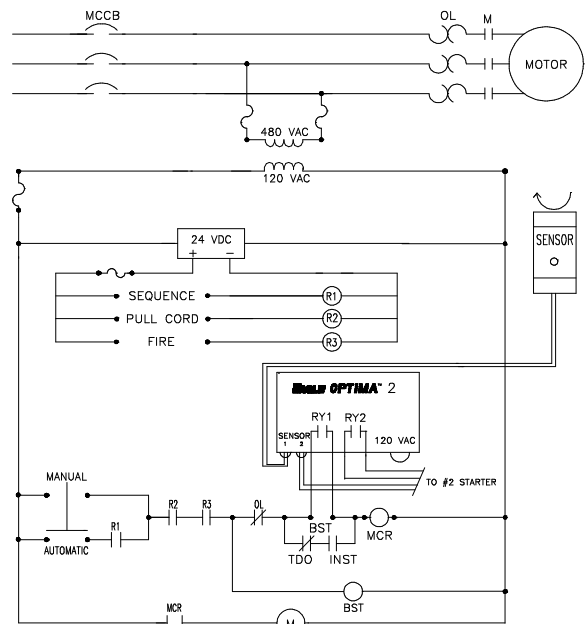

FIGURE 1