



238 Pillow Street
Butler, PA 16001
724-283-4681
724-283-5939 (fax)
www.bwieagle.com

PRODUCT INFORMATION BULLETIN

OPTIMA T1 Single Channel Critical Speed Switch MODEL 13-7100

DESCRIPTION

The model 13-7100 is one in a series of critical speed switches that monitor speed and detect motion in all types of machinery and apparatus. Complete with ramp-up timer, the 13-7100 monitors speed ranges of 60 - 800 RPMs. Models are available to meet any application requirement for underspeed, overspeed or zero speed detection. The OPTIMA T1 utilizes a non-contacting proximity sensor that may be remotely located up to two miles from the control unit. Its rugged NEMA enclosure, with up-front display, is well-suited to meet the environmental challenges of any industry. Ideal for conveyors, crushers, fans, motors and other rotating apparatus.

INSTALLATION

Disconnect AC power before proceeding with installation

- Make the following connections:
 - The 9V memory battery on the PC Board must be plugged in during installation.
 - Connect power cable to switched 120 VAC.
 - Connect control cable to appropriate terminals in the motor control circuit.
 - Connect the EAGLE PROX SENSOR to the connector on the control unit.
- Install sensor at roller or shaft. See sensor installation sheet.

SET-UP AND TESTING

Final calibration should be performed with the belt loaded and running at normal speed.

- Turn SPEED control (R13) CCW until it stops. (Approximately 7 o'clock)
- Hold TEST/SET switch in the SET position to energize relay (RY1).
- Turn SPEED control CW SLOWLY, until CRITICAL LED (LED 53) stays on continuously.
- Continue turning SPEED control until MARGIN LED (LED 3) begins to blink.**
- After the RELAY STATUS LED (LED 7) is illuminated, return the TEST/SET switch to the RUN (center) position.
- A momentary TEST position is provided to simulate the loss of sensor signal which releases the control relay.
- Set delay timer (R42) for desired ramp-up period.

*** Using the above calibration, the control relay will drop out at a machinery slow down of approximately 15%. For a 20% margin, adjust the SPEED control so that the MARGIN LED just comes on steady. For a 10% margin, adjust the SPEED control CCW so that the MARGIN LED has just gone out. If a margin greater than 20% is desired, consult BWI Eagle, Inc. For ALL speed adjustments, the CRITICAL SPEED LED must stay on continuously.



CONTROLS AND INDICATORS

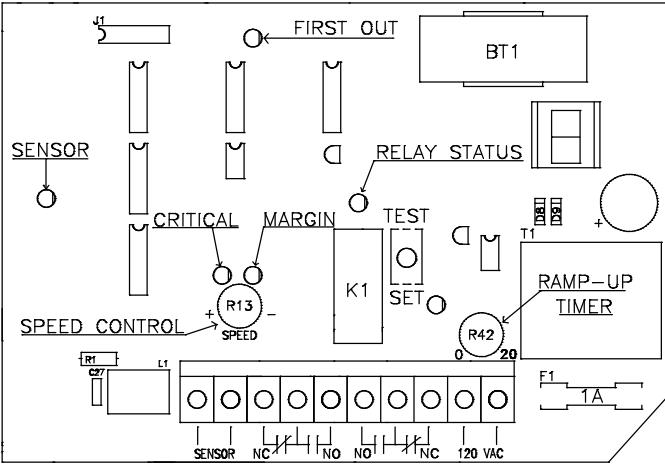

TERMINAL STRIP WIRING

The OPTIMA unit is shipped with the control cables installed on the normally open contacts. The control cables should be installed directly in the series circuit driving the motor control relay. (See TYPICAL BELT STARTER) The additional contacts supplied on the printed circuit card can be used, but the First-Out capability is only installed on the one set of normally open contacts per channel.

CHANNEL 1		120 VAC	
1	Sensor (+)	9	120 VAC
2	Sensor (-)	10	120VAC
3	N/C		
4	Common (1 st OUT)		
5	N/O (1 st OUT)		
6	N/O		
7	Common		
8	N/C		

OPTIMA T1

Single Channel Critical Speed Switch

MODEL 13-7100

FIRST OUT OPERATION

The EAGLE OPTIMA "First Out" capability enables the user to visually see (by an LED indicator) if the slip switch relay contacts were the first to open. Once the belt is running and the control relay in the OPTIMA unit has energized, the First-Out indication (if activated) will extinguish. If the belt begins to slip and the OPTIMA unit shuts the drive down, the First-Out LED will illuminate. This LED will stay lit until the belt is restarted and the control relay in the Optima has energized. If R1, R2, or R3 (See TYPICAL BELT STARTER) would open, this would shut the drive down and also the slip switch contacts would open. But, the First-Out LED would not be illuminated. This would allow the user to see that the slip switch relay contacts were not the first to open and cause the shutdown.

FRONT COVER INDICATORS

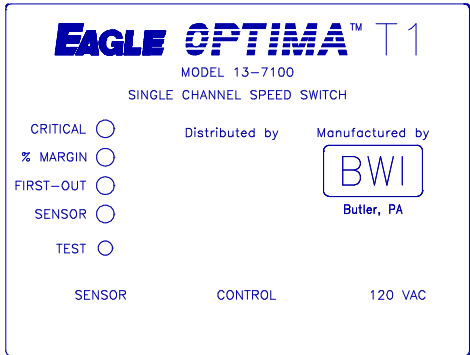

CRITICAL SPEED LED - Must be illuminated continuously to allow control relay to energize.

MARGIN LED - Indicates the percentage of slip the user has calibrated the unit for: (Out = 10%, Blinking = 15%, Solid = 20%)

FIRST-OUT LED - When illuminated, indicates that the OPTIMA unit has caused the shutdown.

SENSOR LED - Pulses at the rate of speed being received by the sensor.

TEST SWITCH - When pushed, simulates a loss of sensor signal which will drop out the control relay.

SPECIFICATIONS

AC Input	120 VAC @15 W with belt running
Fuse Protected	1 amp
Battery	9v Rechargeable
First-Out Indicator	If illuminated after a shutdown, will indicate for approx. 8 hrs on a full charge
Battery Charge Time	Fully charged in 14 hours
Speed Range	60 - 800 RPM
Relay Contacts	DP/DT 8 amp @ 120 VAC
First-Out Current Range	17mA - 8 amps
Start-up Timer	0 - 20 Seconds, Adjustable
Response Time	1 Second or Less
Enclosure	NEMA 12 Standard

DIMENSIONS

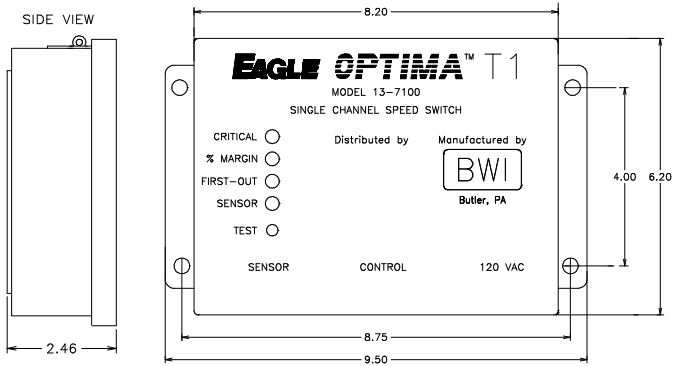

REPLACEMENT AND OPTIONAL PARTS

DESCRIPTION	PART NO.
P.C. Board	13-7102
Proximity Sensor, General Mount	10-7135
Relay	99-REL-0001
Strain Relief (Power Input)	99-CON-0011
Strain Relief (Control)	99-CON-0012

TYPICAL BELT STARTER

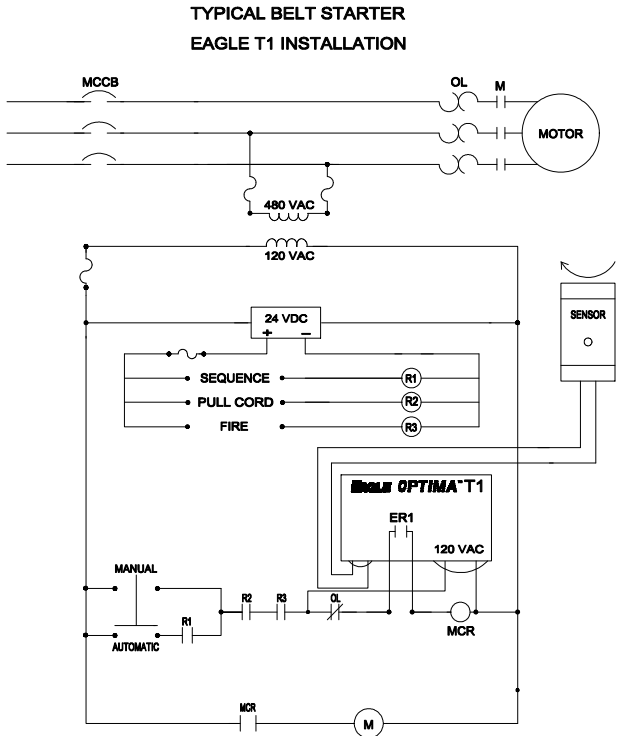

FIGURE 1