

### OVERVIEW

The WECT400/410 Cooling Tower Controllers with electrodeless (toroidal) conductivity sensors represent the latest in technological and innovative advancements from Walchem. The electrodeless sensor is impervious to contamination by oils, scale, biofilm, or other coatings, resulting in a low maintenance system that provides reliable, effective control.

All of the standard features you'd expect in a conventional cooling tower controller are included, plus optional simple-to-use information management tools that enable water treatment professionals to deliver more effective service to their customers. The WECT400/410 controllers have the ability to store conductivity and temperature values, water usage, relay and flow switch status, and user settings. A USB stick is all that's needed to extract the information. Download logs from the USB stick to a PC at your convenience, or copy your preferred treatment program from to another controller to speed start-up. It couldn't be easier!



### SUMMARY OF KEY BENEFITS



#### Ensures Optimal Performance and Maximum Efficiency

Precise control of conductivity and chemical feed reduces water consumption and inhibits corrosion, solids precipitation, scale build-up and growth of algae or dangerous bacteria.



#### Spend More Time Selling

Electrodeless conductivity sensor is impervious to contamination and coatings, which means you'll spend less time cleaning and calibrating sensors and spend more time selling!



#### Efficient Customer Service

Quickly identify system upsets by knowing exactly what happened and when. An event log can be downloaded to tell you precisely when pumps turned on, valves opened, and when there was flow or no-flow.



#### More Informative Monthly Reports

Download stored data from the controller to a USB flash stick. Use the data to easily develop reports that validate and verify water treatment results, and include actual water usage, system conductivity, temperature, and accumulated chemical feed and bleed times.



#### Save Time

Copy the user settings from your controller to a USB flash stick and upload to a new controller. Programming your new controller this way can be accomplished in seconds. It's that simple!



## WECT400 Series | Feed and Bleed Cooling Tower Controller

### » Four chemical feed options

- Feed & bleed, with or without feed lockout timer
- Feed after bleed has finished, as a percentage of time
- Feed as a percentage of time elapsed
- Feed as a percentage of make-up water

### » Self-Diagnostics

- Software, electronics, and sensor are constantly monitored without having to take controller offline.

### » Conductivity Sensor

- Electrodeless, temperature compensation, CPVC
- In-line or submersion

### » 4-20mA Output

- Optional isolated 4-20mA output proportional to the conductivity reading.

### » Flow Switch Manifolds

- Optional integrated flow switch manifold may be panel mounted for quick, professional installation with only two process connections.

### » Flow Meter Input

- Accommodates a wide range of contacting and Hall Effect water meters

### » USB Flashstick Support

- Optional for data logs, event/relay and reset logs, and user configuration file import/export

## WECT410 Series | Feed and Bleed Cooling Tower Controller with Dual Biocide Timers

The WECT410 Series offers all of the WECT400 features as well as:

### » Programmable Dual Biocide Timers

- Choice of 1, 7, 14, or 28-day cycles
- Able to: add a single biocide at any time or dual alternating biocides, or dual independent biocides

### » Alarm Output Relay

- Triggered by low conductivity, high conductivity, no-flow conditions, bleed timeout, sensor error, and temperature error

## Optional USB Features

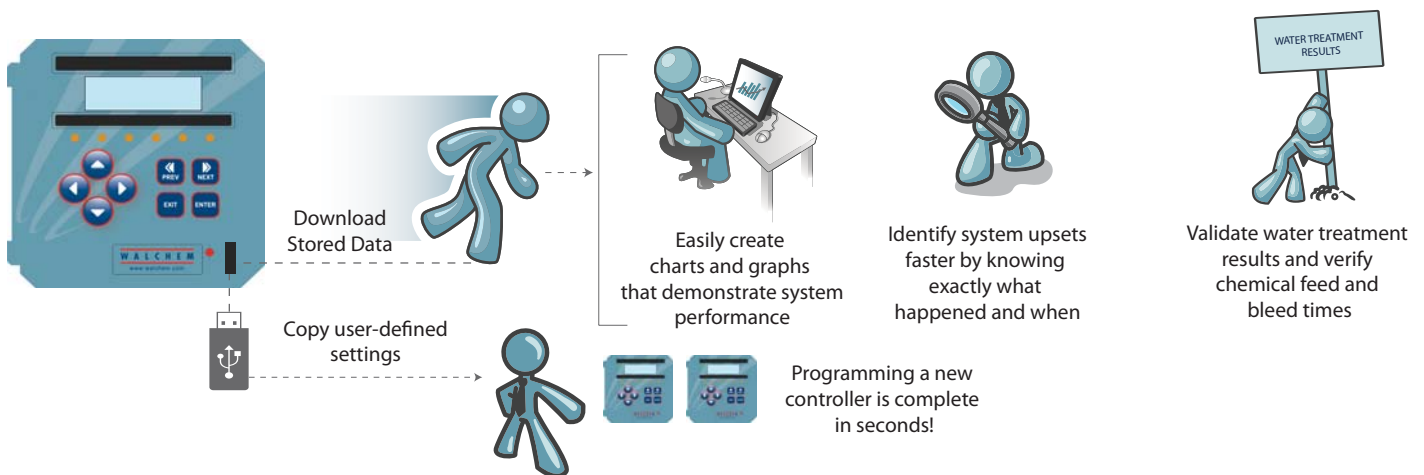

TYPICAL INSTALLATION

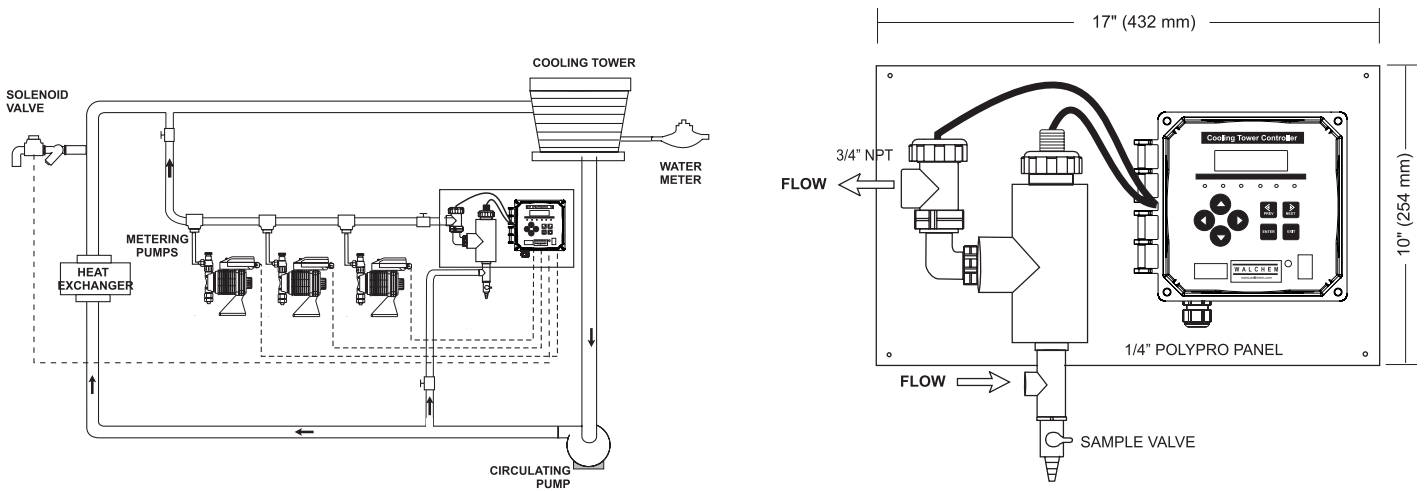

Inputs

Power

100-240 VAC, 50/60 Hz, 8A  
Fuse: 1.0 ampere, 5 x 20 mm

Signals

Cond Sensor: 1.0 cell factor, 10K thermistor  
Flow Meter (optional): Isolated, dry contact closure required (i.e. relay, reed switch)  
Flow Switch (optional): Isolated, dry contact closure required (i.e. reed switch)

Measurement Performance

**Conductivity Range** 100-10,000  $\mu\text{S}/\text{cm}$   
**Resolution** 1  $\mu\text{S}$   
**Accuracy**  $\pm 1\%$  of reading  
**Temperature Range** 32 to 158°F (0 to 70°C)  
**Resolution** 0.1 degree  
**Accuracy**  $\pm 1\%$  of reading

Flow Switch Manifold & Sensor Specifications

Standard

Process connections 3/4" NPTF  
Temperature 140°F (60°C)  
Pressure 150 psi up to 100°F (38°C)  
50 psi at 140°F (60°C)

Materials of construction

Standard electrode CPVC  
Flow switch manifold GFRPP, PVC, Isoplast, FKM

Outputs

Mechanical Relays

WECT400: Two powered relays (Bleed, Feed)  
WECT410: Five powered relays (Bleed, Feed, Bio 1, Bio 2, Alarm)  
6 A (resistive), 1/8 HP  
All relays are fused together as one group, total current for this group must not exceed 6A

4 - 20 mA (optional)

Internally powered  
Fully isolated  
600 Ohm max resistive load  
Resolution .001% of span  
Accuracy  $\pm 1\%$  of reading

Mechanical

**Enclosure** Polycarbonate  
**NEMA Rating** NEMA 4X (IP65)  
**Display** 2 x 16 character backlit liquid crystal  
**Ambient Temperature** 32 to 122°F (0 to 50°C)  
**Shipping weight** 7 lbs (3 kg) (approximately)

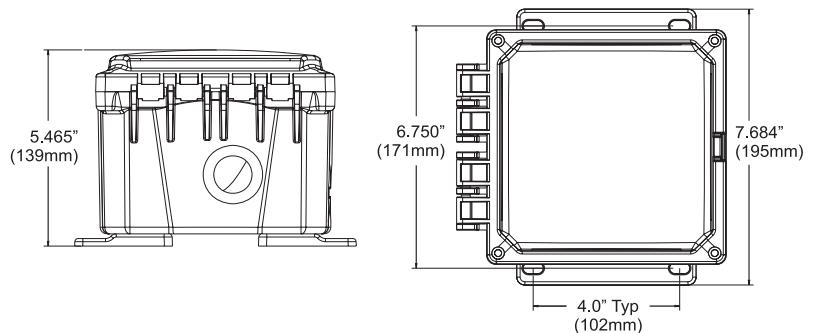

## ORDER INFORMATION

WECT400      
 WECT410 voltage output sensor USB

### VOLTAGE

1 = 120 VAC, prewired  
 5 = 100-240 VAC, hardwired, cable glands

### OUTPUT

N = No analog output  
 4 = Single Isolated 4-20 mA output

### SENSOR

N = No electrode  
 1 = Electrodeless conductivity sensor & tee, 20 ft. cable (for inline mounting)  
 2 = Electrodeless conductivity sensor & flow switch manifold on PP panel, 5 ft. cable  
 2L= Electrodeless conductivity sensor & flow switch manifold (loose, no panel), 20 ft. cable  
 3 = Submersion conductivity sensor (no tee or adapter), 20 ft. cable

### USB FEATURES

N = Software upgrade capability only  
 U = Integrated datalogging, event/reset logging, and configuration file import/export

## AGENCY CERTIFICATIONS

UL ANSI/UL 61010-1:2004, 2nd Edition\*  
 CAN/CSA C22.2 No.61010-1:2004 2nd Edition\*  
 CE Safety EN 61010-1 2nd Edition (2001)\*  
 CE EMC EN 61326 :1998 Annex A\*

Note: For EN61000-4-6,-3 the controller met performance criteria B.

\*Class A equipment: Equipment suitable for use in establishments other than domestic, and those directly connected to a low voltage (100-240 VAC) power supply network which supplies buildings used for domestic purposes.



### Webmaster®ONE

WebMasterONE is the most advanced online cooling tower and boiler controller in the water treatment industry. The flexible multi-I/O platform allows you to control multiple cooling towers, boilers, closed loops, and condensate lines with just one controller. An extensive assortment of integrated communications and data handling features are included that enable water treatment professional to provide more effective water management services to their customers.



### Metering Pumps

The E-Class is the most innovative and comprehensive metering pump product line in the world. Over 50 years of pump experience and a commitment to superior mechanical design has led to development of many industry firsts, including 360 stroke-per-minute technology, IP67 waterproof construction, and the world's highest capacity solenoid metering pumps.



### WIND WebMaster® Industrial Water Controllers

Walchem's WebMaster Industrial (WIND) Controller sets a new standard for Industrial Water Treatment Controllers. WIND has a flexible multi-I/O platform, a wide range of analytical sensor measurement capabilities, and an extensive assortment of integrated communications and data handling features.



### WebAlert® Remote Monitor

Walchem's WebAlert is the first stand alone remote monitoring device that can web enable your installed equipment without having to replace or upgrade it.

## ABOUT US

Walchem integrates its advanced sensing, instrumentation, fluid pumping and communications technologies to deliver reliable and innovative solutions to the global water treatment market

Our in-house engineering is driven by quality, technology and innovation. For more information on the entire Walchem product line, visit: [www.walchem.com](http://www.walchem.com)



An Iwaki America Company

Walchem, An Iwaki America Corporation Company  
 Five Boynton Road Hopping Brook Park  
 Holliston, MA 01746 USA  
 Phone: 508-429-1110  
 Fax: 508-429-7433  
[www.walchem.com](http://www.walchem.com)